



TC-910R_i

TWO STAGE CONTROLLER FOR REFRIGERATION

Ver.01



TC910V01-05T-110-48

1. DESCRIPTION

The **TC-910R_i** is a temperature controller for freezing goods with two stages for freezing. It also commands the evaporator fans and manages the defrosting cycles.

It includes two independent hourmeters for counting the refrigeration output operation time. When the programmed amount of hours before maintenance is reached (ex: compressors) a display indication is given.

In order to increase the system efficiency, the **TC-910R_i** allows the adjustment of a pre-defrosting time, which enables the collection of remaining gas before starting the defrosting cycle.

Product in agreement with CE (European Community)

2. APPLICATION

- Counters
- Refrigerating balconies

3. TECHNICAL SPECIFICATIONS

- Power supply: TC910Ri - 115 or 230Vac ±10%(50/60Hz)
TC910RiL - 12 or 24Vac/dc
- Control temperature: -50 to 75 °C / -58 to 167 °F
- Operating temperature: 0 to 50 °C / 32 to 122 °F
- Operating humidity: 10 to 90% RH (without condensation)
- Resolution: 0.1 °C from -10 to 75 °C and 1 °C outside this range
1 °F in all range
- Load current (outputs): REF1: 5(3)A/250Vac 1/8HP (compressor, solenoid valve or contactor)
REF2: 5(3)A/250Vac 1/8HP (compressor, solenoid valve or contactor)
FANS: 5(3)A/250Vac 1/8HP (evaporator fans)
DEFR: 5(3)A/250Vac (defrost - resistance or hot gas)
- Dimensions: 71 x 28 x 71mm
- Sensors:
S1: Room sensor - Black cable
S2: evaporator sensor - Gray cable

CLASSIFICATION ACCORDING TO IEC60730-2-9 STANDARD:

- Temperature limit of the installation surface: 50 °C
- Type of construction: Built-in electronic controller
- Automatic action: Type 1
- Control of pollution: Level 2
- Impulse voltage: 1,5kV
- Temperature for the test of sphere pressure: 75 °C and 125 °C
- Insulation: Class II

4. CONFIGURATIONS

4.1 - Control temperatures adjust (SETPOINTS):

- Press **SET** for 2 seconds until appears **5EE**, and release it after that. It will appear **5P1** and the working temperature adjusted. Use **▼** and **▲** keys to change the value and then press **SET** to record it. Soon after it **5P2** (economic setpoint) will appear, repeats the procedure above to modify the value and leave the function.

4.3 - Parameters description

F01 - Access code (123)

To change the parameters it is necessary to use the access code. It is not necessary to use the access code to visualize the adjusted parameters.

F02 - Control differential for the 1st stage (hysteresis 1)

It is the difference of temperature (hysteresis) between to turn OFF and turn ON the 1st stage (REF1).
Example: To control the temperature in 4.0 °C with differential of 1.0 °C. Soon, the refrigeration will be turned off in 4.0 °C and turned on again in 5.0 °C (4.0 + 1.0)

F03 - Control differential for the 2nd stage (hysteresis 2)

It is the difference of temperature (hysteresis) between to turn OFF and turn ON the 2nd stage (REF2).

F04 - Minimum setpoint allowed to the end user

F05 - Maximum setpoint allowed to the end user

Electronic limits whose purpose is prevent that too high or too low setpoint temperatures are regulated.

F06 - Delay when the instrument is powered on

When the instrument is powered on, its control is kept disabled during a time, delaying the start of process. During this time, it works only as temperature indicator. It serves to prevent demand of electric energy peaks, in case of lack or return of the same and when exists a lot of equipment connected on the same net. For this, just adjust different times for each equipment. This delay may be of compressor or defrost (when exist defrost on turn on).

F07 - Act point of high room temperature alert

If the room temperature (sensor S1) reaches this point during refrigeration, this will be signaled visually through the indication blinking on display.

08 - Refrigeration time (interval between defrosts)

It is the time which compressor will turn on and turn off only for room temperature and starts to be counted when the fan is turned on, after fan-delay stage (fan return after draining).

Attention, the defrost will only initiate if the temperature in S2 (sensor of the evaporator) will be lesser of what the indicated one in F13.

F09 - Compressor delay after on (on-off)

It is the minimum time that compressor will keep on, it means, space of time between the last drive and the next stop. It serves to prevent high voltage events in the electric network.

F10 - Compressor delay after off (off-on)

It is the minimum time that compressor will keep off, it means, space of time between the last stop and the next drive. It serves to alleviate the discharge pressure and to increase the time of useful life of the compressor.

F11 - Compressor status with detached ambient sensor (S1)

If the room sensor (S1) will be danified or outside the specified range, the compressor assumes the configured status in this function.

Example: For counters of fruits, it is better to keep the compressor off. In counters of meat it is better to keep the compressor on.

F12 - Defrost when the instrument is powered on

It makes possible the accomplishment of a defrost at the moment that controller is energized, for example, in the return of electrical energy (in case of energy lack)

Fun	Description
F01	Access code:123 (one hundred and twenty-three)
F02	Control differential for the 1st stage (hysteresis 1)
F03	Control differential for the 2nd stage (hysteresis 2)
F04	Minimum setpoint allowed to the end user
F05	Maximum setpoint allowed to the end user
F06	Delay when the instrument is powered on
F07	Act point of high room temperature alert (S1)
F08	Refrigeration time (interval between defrosts)
F09	Compressor delay after on (on - off)
F10	Compressor delay after off (off - on)
F11	Compressor status with detached ambient sensor (S1)
F12	Defrost when the instrument is powered on
F13	Evaporator temperature (S2) for end defrost
F14	Maximum duration of defrost (for security)
F15	Fan turned on during defrost
F16	Defrost type
F17	Locked temperature indication (S1) during defrost
F18	Draining time (dripping of defrost water)
F19	Evaporator temperature (S2) for fan return after draining
F20	Maximum time of fan return after draining (fan-delay)
F21	Fan on with compressor off (refrigeration)
F22	Fan stopped for high temperature in the evaporator
F23	Offset indication for ambient sensor (Offset S1)
F24	Offset indication for evaporator sensor (Offset S2)
F25	Pre-defrosting time
F26	Max. operation time for output REF1 before maintenance.
F27	Max. operation time for output REF2 before maintenance

CELSIUS				FAHRENHEIT			
Min	Max	Unit	Default	Min	Max	Unit	Default
-	-	-	-	-	-	-	-
1	20.0	°C	1.5	1	36	°F	3
1	20.0	°C	1.5	1	36	°F	3
-50.0	75.0	°C	-50	-58	167	°F	-58
-50.0	75.0	°C	75	-58	167	°F	167
0	30	min.	0	0	30	min.	0
-50.0	75.0	°C	75	-58	167	°F	167
1	999	min.	240	1	999	min.	240
0	999	sec.	0	0	999	sec.	0
0	999	sec.	0	0	999	sec.	0
0 - off	1 - on	-	1 - on	0 - off	1 - on	-	1 - on
0 - no	1 - yes	-	0 - no	0 - no	1 - yes	-	0 - no
-50.0	75.0	°C	40	-58	167	°F	104
0 - disable	90	min.	45	0 - disable	90	min.	45
0 - no	1 - yes	-	0 - no	0 - no	1 - yes	-	0 - no
0 - electric	1 - hot gas	-	0 - electric	0 - electric	1 - hot gas	-	0 - electric
0 - no	1 - yes	-	0 - no	0 - no	1 - yes	-	0 - no
0	30	min.	10	0	30	min.	10
-50.0	75.0	°C	0	-58	167	°F	32
0	30	min.	1	0	30	min.	1
0 - no	1 - yes	-	1 - yes	0 - no	1 - yes	-	1 - yes
-50.0	75.0	°C	75	-58	167	°F	167
-20.0	20.0	°C	0	-36	36	°F	0
-20.0	20.0	°C	0	-36	36	°F	0
0	120	seg.	0	0	120	seg.	0
0 - disable	999	x10h	500	0 - disable	999	x10h	500
0 - disable	999	x10h	500	0 - disable	999	x10h	500

F13 - Evaporator temperature (S2) for end defrost
If the temperature in the evaporator (sensor S2) reaches the adjusted value, the end of defrost will be for temperature. With this, the defrost process is optimized.

F14 - Maximum duration of defrost (for security)
This function serves to adjust the maximum value of time for defrost. If evaporator temperature does not reach the configured value in F13 in this period a point will blink in the right down side of display indicating that end of defrost occurred for time and not for temperature.
The end of defrost by time (which is not desired) can happen on the following situations:
- Adjusted temperature (F13) too high;
- Maximum time of defrost (F14) too short;
- Detached S1 sensor or without contact with evaporator.

F15 - Fan turned on during defrost
It makes possible the fan functioning during defrost.
Example: Natural defrost or by resistances installed outside the evaporator.

F16 - Defrost type
"0" = Electrical defrost (resistances), where the defrost output is active.
"1" = Defrost by hot gas, where compressor and defrost outputs are actives.

F17 - Locked temperature indication (S1) during defrost
This function prevents that room temperature elevation during defrost be visualized, keeping the last indication before defrost. The indication is released again in the initial of refrigeration cycle, after fan-delay.

F18 - Draining time (dripping of defrost water)
Necessary time for dripping, it means, for draining the last water drops of evaporator. All the outputs are kept off. If this stage will not be desired, adjust this time for "zero".

F19 - Evaporator temperature (S2) for fan return after draining (fan-delay)
The fan-delay cycle starts after draining. The refrigeration output (REF1) is active, therefore the ambient temperature is high, but the fan is actived only after the temperature in evaporator is less than the adjusted value. This process is necessary to remove the heat that still exists in the evaporator because of defrost, preventing to transfer this heat to the ambient.

F20 - Maximum time of fan return after draining (fan-delay)
For security, if the temperature in the evaporator does not reach the adjusted value in F19 or sensor S2 is detached, the fan-delay will happen on the adjusted time in this function.

F21 - Fan on with compressor off
During the refrigeration cycle, the fan activation may depends on the compressor status.
"0" = The fan is actived only while the compressor is active. This alternative, in some cases, allows great economy of electric energy.
"1" = The fan is kept on during all refrigeration cycle.

F22 - Fan stopped for high temperature in evaporator
It has for purpose the cycle of evaporator ventilation until the ambient temperature approaches the desired temperature in the refrigerating installation project, preventing high temperatures and pressures that can damage the compressor. If the temperature in evaporator exceed the adjusted value, the fan is turned off and turned on again with a fixed hysteresis of 2°C below this value. Valuable resource when refrigeration equipment that had been inactive for a few days or refrigerated cases are restocked with its proper merchandise.

F23 - Offset indication for ambient sensor (Offset S1)
F24 - Offset indication for evaporator sensor (Offset S2)
It allows to compensate eventual shunting lines on reading of ambient or evaporator sensor (S1 or S2), proceeding of sensor exchange or cable length alteration.

F25 - Pre-defrosting time
This is to collect the remaining gas from the refrigerating gas line before starting the defrosting cycle, thus increasing the system efficiency. Only the FANS output remains ON during this time.

F26 - Max. operation time for output REF1 before maintenance.
This allows to configure an operation time (hours x 10) for output REF1 in order to indicate the need of maintenance for the first compressor. When this operation time is reached, the display shows **H-1** and can be reset by the user at this point.

F27 - Max. operation time for output REF2 before maintenance
This allows to configure an operation time (hours x 10) for output REF2 in order to indicate the need of maintenance for the first compressor. When this operation time is reached, the display shows **H-2** and can be reset by the user at this point.

5. OPERATION

5.1 - Parameters visualization

- Press at the same time **▼** and **▲** for 2 seconds until appear **F0n**, releasing them after that. Soon, appears **F01**.
- Use **▼** and **▲** to access the desired function.
- After selecting the function, press **SET** (short touch) to visualize the configured value.
- Press again **SET** (short touch) to return the functions menu.
- To reset the menu and return to normal operation (temperature indication), press **SET** until appear **---**.

5.2 - Parameters configuration

- Access the function F01 by pressing at the same time **▼** and **▲** for 2 seconds until appear **F0n**, releasing then after that. Soon will appear **F01**, and then press **SET** (short touch).
- Use **▼** and **▲** to enter the access code, and then press **SET**.
- Select the desired function and visualize the configured value (see itens 5.1-b and 5.1-c).
- Use **▼** and **▲** to change the value and then press **SET** to record the configured value and return to the functions menu.
- To reset the menu and return to normal operation (temperature indication), press **SET** until appear **---**.

5.3 - Process stage, elapsed time, sensors S2 temperature e hourmeter time.

Press **▼**. The stage of the process will appear, the elapsed time (in minutes), the evaporator temperature (sensor S2), and the elapsed times of each hourmeter (in hours).

Process stages: **dEL** Initial delay (delay to start the control)
FAn Fan-delay (delay to fan return)
rEF Refrigeration
dEF Defrost
drE Draining

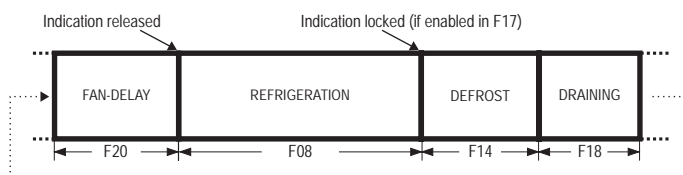

5.4 - Manual defrost

To do a manual defrost, regardless of the programming, keep pressed **▲** for 4 seconds, until appears the indication **dEFFOn**.
If the instrument is in defrost and you want to finish it, follow the above instructions, until appears the indication **dEFFOFF**.

5.5 - How to determine the end defrost by temperature

- Adjust the follow functions with maximum values:
 - Refrigeration time (F08 = 999 min)
 - Evaporator temperature for end defrost (F13 = 75.0°C)
 - Maximum duration of defrost (F14 = 90 min)
- Wait until an ice layer to be created on the evaporator
- Do a manual defrost, pressing **▲** for 4 seconds, until appear **dEFFOn**.
- Observe the melting process.
- Wait until melt all ice layer on the evaporator to consider the defrost finished.
- Check the evaporator temperature read by the sensor S2 at this moment, pressing the key **▼** and copy this value to the function F13 - Evaporator temperature (S2) for end defrost.
- As security, adjust again the function F14 - Maximum duration of defrost, that depends of the defrost type.
*Example: Electrical defrost (resistance) = 45 minutes as maximum
Defrost for by hot gas = 20 minutes as maximum*
- Now adjust the function F08 - Refrigeration time, with the desired value.

5.6 - Minimum and maximum temperatures register

Press **▲**, soon **E-1** appears and the minimum and maximum temperatures of S1 sensor (room temperature). After soon **E-2** appears and the minimum and maximum temperatures of S2 sensor (evaporator).

Note: To reset the registers keep pressed the key **▲** during the visualization of the minimum and maximum temperatures until **rSE** to be showed.

5.7 - How to reset an alarmed hourmeter to zero

Press **▼** for 10 seconds until **rSE** is displayed to reset any alarmed hourmeter to zero.

6 - INDICATORS AND ALARMS

The leds indicate the control outputs status:

REF1: Compressor or solenoid of liquid gas;

REF2: Compressor or solenoid of liquid gas;

FANS: Evaporator fans;

DEFR: Defrost (heating);

E-1: Room sensor S1 disconnected or out of range;

E-2: Evaporator sensor S2 disconnected or out of range;

H-1: Alarm for output REF1 hourmeter;

H-2: Alarm for output REF2 hourmeter;

H-H: Sensor 1 high temperature alarm;

---: Always that defrost ends for time and not for temperature, a point located in the right down side of display will blink until the next defrost indicating that:

- The interval between defrosts is too high;
- There are burned resistances;
- The hot gas is not circulating;
- There is an inoperative fan or the adjusted time is too short for the maximum duration of defrost.

PPP: Invalid configuration parameters

- In this situation the outputs are turned off;

- Check which parameters have invalid data and correct them to return to normal operation.

7 - UNIT SELECTION (°C / °F)

To determine the unit that the instrument will work, access the function "F01" with the access cod 231 and confirm with the key **SET**. Press the key **▲**. **Un1** will appear. Press **SET** than use **▼** or **▲** to choose between **0C** or **0F** and confirm with **SET**. After select the unit **F01** will appear and the instrument returns to the function "F01". Every time that the unit is changed, the parameters must be configurated again, because they assume the standard values.

8. WIRING DIAGRAM

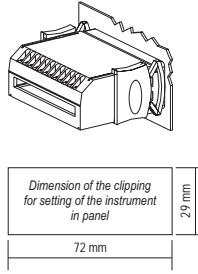
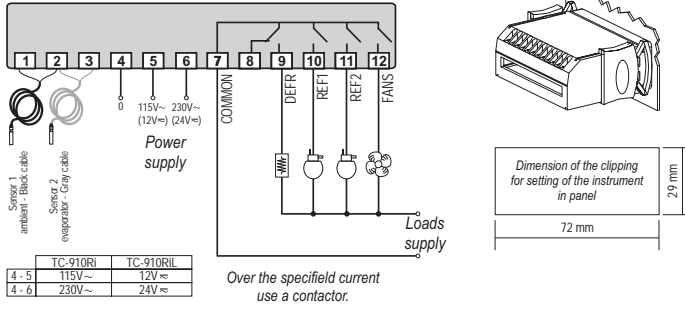

Note: The sensor cable length can be increased by the user until 200 meters using PP 2 x 24 AWG cable.

IMPORTANT

According to the chapters from the IEC60364 standard:

- 1: Install protectors against over voltage on power supply
 - 2: Sensor cables and computer signals can be together, however not at the same place where power supply and load wires pass for
 - 3: Install suppressor of transient (RC filters) in parallel to loads to increase the usefull life of the relays
- For more information contact our application eng. department through e-mail support@fullgauge.com or dial +55 51 3475.3308.

Contact suppressor connection diagram

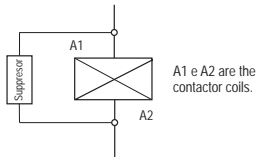
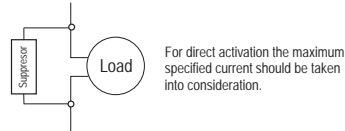

Diagram for suppressor installation for direct drive load inputs



PROTECTIVE VINYL:

This adhesive vinyl (included inside the packing) protects the instruments against water drippings, as in commercial refrigerators, for example. Do the application after finishing the electrical connections.

Remove the protective paper and apply the vinyl on the entire superior part of the device, folding the flaps as indicated by the arrows.

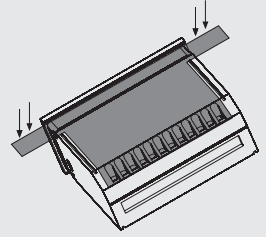

© Copyright 2006 • Full Gauge Controls® • All rights reserved.